

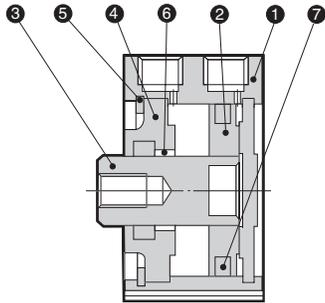

构造图



主要零件

No.	零件名称	材 质
1	缸体	铝合金
2	活塞	铝合金
3	活塞杆	碳钢
4	前端盖	铝合金
5	挡圈	铜
6	轴套	树脂
7	活塞密封圈	NBR

外形尺寸图

两端母螺纹部尺寸

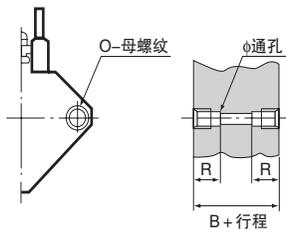

缸筒内径 (mm)	O	R
12	M4 × 0.7	7
16	M4 × 0.7	7
20	M6 × 1.0	10
25	M6 × 1.0	10
32	M6 × 1.0	10
40	M6 × 1.0	10
50	M8 × 1.25	14
63	M10 × 1.5	18
80	M12 × 1.75	22
100	M12 × 1.75	22

活塞杆前端公螺纹

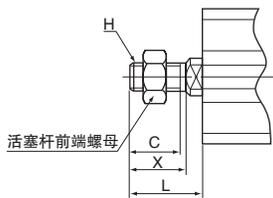

缸径 (mm)	C	X	φ D	H	L	K
12	9	10.5	6	M5 × 0.8	14	5
16	10	12	8	M6 × 1.0	15.5	6
20	12	14	10	M8 × 1.25	18.5	8
25	15	17.5	12	M10 × 1.25	22.5	10
32	20.5	23.5	16	M14 × 1.5	28.5	14
40	20.5	23.5	16	M14 × 1.5	28.5	14
50	26	28.5	20	M18 × 1.5	33.5	17
63	26	28.5	20	M18 × 1.5	33.5	17
80	32.5	35.5	25	M22 × 1.5	43.5	22
100	32.5	35.5	30	M22 × 1.5	43.5	27

外螺纹部

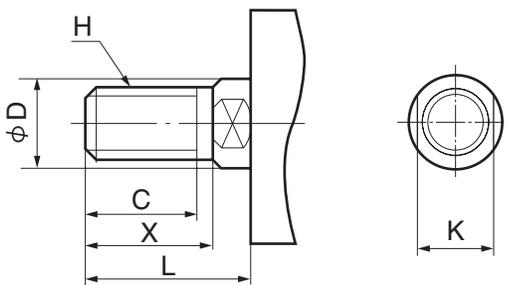

缸筒内径 (mm)	C	X	φ D	H	L	K
12	9	10.5	6	M5 × 0.8	14	5
16	10	12	8	M6 × 1.0	15.5	6
20	12	14	10	M8 × 1.25	18.5	8
25	15	17.5	12	M10 × 1.25	22.5	10
32	20.5	23.5	16	M14 × 1.5	28.5	14
40	20.5	23.5	16	M14 × 1.5	28.5	14
50	26	28.5	20	M18 × 1.5	33.5	17
63	26	28.5	20	M18 × 1.5	33.5	17
80	32.5	35.5	25	M22 × 1.5	43.5	22
100	32.5	35.5	30	M26 × 1.5	43.5	27

外形尺寸图

(mm)

EEMB

φ 12 ~ φ 25

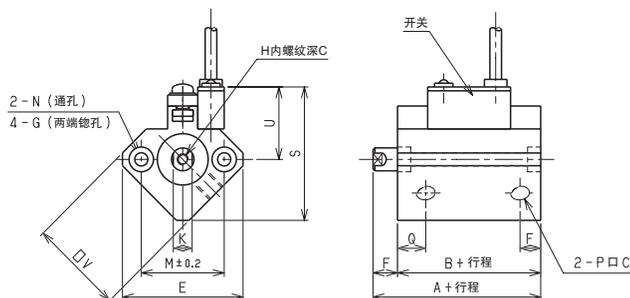

φ 32 ~ φ 100

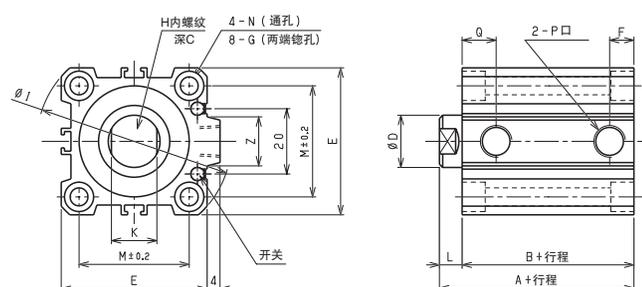

EEMA

φ 12 ~ φ 25

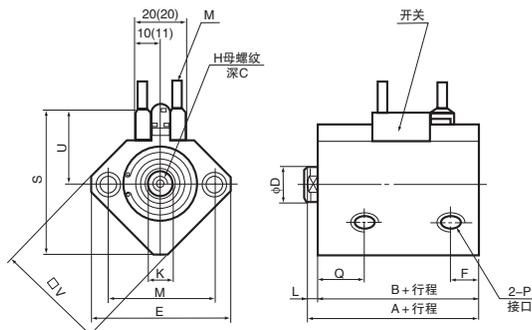

φ 32 ~ φ 100

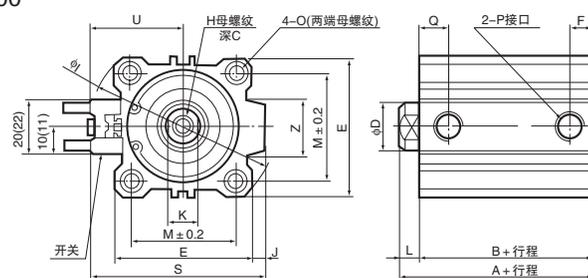

缸筒内径 (mm)	行程范围 (mm)	A	A*	B	B*	D	E	F	F*	G	H	C	I	J	K	L	M	N	O	P	Q	S	U	V	Z
12	5~30	20.5	31.5	17	28	6	32	5	6.5	6.5深3.5	M3×0.5	6	-	-	5	3.5	22	3.5	6.5深3.5	M5×0.8	7.5	35.5	19.5	25	-
16	5~30	22	34	18.5	30.5	8	38	5.5	5.5	6.5深3.5	M4×0.7	8	-	-	6	3.5	28	3.5	6.5深3.5	M5×0.8	8	41.5	22.5	29	-
20	5~50	24	36	19.5	31.5	10	46.8	5.5	5.5	9深7	M5×0.8	7	-	-	8	4.5	36	5.5	9深7	M5×0.8	9	48	24.5	36	-
25	5~50	27.5	37.5	22.5	32.5	12	52	5.5	5.5	9深7	M6×1.0	12	-	-	10	5	40	5.5	9深7	M5×0.8	11	53.5	27.5	40	-
32	5	30	40	23	33	16	45	5.5	7.5	9深7	M8×1.25	13	60	4	14	7	34	5.5	9深7	M5×0.8	11.5	58.5	31.5	-	18
	G1/8																			10.5					
40	5~50	36.5	46.5	29.5	39.5	16	52	8	8	9深7	M8×1.25	13	69	5	14	7	40	5.5	9深7	G1/8	11	66	35	-	18
50	10~50	38.5	48.5	30.5	40.5	20	64	10.5	10.5	11深8	M10×1.5	15	86	7	17	8	50	6.6	11深8	G1/4	10.5	80	41	-	22
63	10~50	44	54	36	46	20	77	10.5	10.5	14深10.5	M10×1.5	15	103	7	17	8	60	9	14深10.5	G1/4	15	93	47.5	-	22
80	10~50	53.5	63.5	43.5	53.5	25	98	12.5	12.5	17.5深13.5	M16×2.0	21	132	6	22	10	77	11	17.5深13.5	G3/8	16	112.5	57.5	-	26
100	10~50	65	75	53	63	30	117	13	13	17.5深13.5	M20×2.5	27	156	6.5	27	12	94	11	17.5深13.5	G3/8	23	132.5	67.5	-	26

\* 磁性气缸尺寸

气缸